

Submersible Grinder Pumps Type ABS Piranha



Main Applications

Sulzer's range of submersible grinder pumps, type ABS Piranha, contain the most effective cutting system for use in pressure sewer systems. The Piranha pumps have proven themselves to be one of the market's best ongoing performers, having excellent total lifecycle costs from initial purchase through ongoing operation.

The Piranha pumps provide a means of effective and economical wastewater transport utilizing small-diameter discharge pipes as opposed to larger diameter pipes required for gravity systems. These pumps are ideally suited for:

- Private residences and community subdivisions
- Municipal wastewater transport
- Commercial wastewater handling of domestic sewage in business parks, restaurants, hospitals, industrial areas, etc.
- Industrial wastewater handling of industrial areas, slaughter houses, food processing plants, paper mills, agricultural applications, etc.
- Hazardous locations requiring certification in accordance with ATEX (EX II 2 G k Ex d IIB T4); FM and CSA available as an option

The Most Effective Cutting System

The Piranha cutter system features a completely different concept in grinder pump design. The design consists of a lobed rotor cutting element attached to a centrifugal impeller working in tandem with a stationary cutting element fastened to a spiral-grooved bottom plate. The lobed rotor turns inside the stationary cutter designed with wave-shaped castellations. The number of waves is one less than the number of lobes on the rotor. This causes an opening to be formed between the rotor and stationary cutter. The normal pumping action of the impeller causes water and solids to flow into the cutting elements and as the solids are sheared into small particles, they are pumped by the impeller into the discharge pipe. Should any of the finely cut particles try to wedge between the impeller and bottom plate, the outward threaded spiral grooves will move them to the discharge.



The Right Installation to Fit Any Need

The Piranha grinder pumps can be installed in several configurations to fulfill virtually any customer requirements, including:

- Fixed installations with pedestal (guide rail assembly)
- Freestanding, transportable applications
- Installation in areas where large fluctuations in terrain elevation are present

Features and Benefits

Piranha PE

Sulzer's premium range of submersible grinder pumps, type ABS Piranha PE, are equipped with Premium Efficiency IE3 Motors in accordance to IEC 60034-20.

Sulzer was the first company in the world to offer Premium Efficiency IE3 submersible motors to achieve the perfect balance of reliability and energy consumption. Utilizing Premium Efficiency IE3 motors and the most effective cutting system, the Piranha grinder pumps are one of the best pumps on the market resulting in zero blockages and low life cycle costs, providing reliability and energy savings.

1 Piranha cutting system

- A spiral-grooved bottom plate and stationary cutting element, combined with a lobed rotor cutting element prior to the impeller provide optimum, blockage-free operation

2 Seal leak detection system

- Advanced warning allows for repair of the pump seal prior to water entering the motor

3 Premium Efficiency Motor (IE3) in accordance to IEC 60034-30

- Low Life Cycle Costs through energy savings
- Significant CO₂ footprint reduction
- Increased lifetime due to low winding temperature rise

4 Double mechanical seals

- Silicon carbide/silicon carbide (SiC/SiC) provides maximum resistance from abrasives
- Seal protection system increases the longevity of the lower seal and reduces maintenance costs
- SiC/SiC is chemical resistant in wastewater and most other industrial applications

5 Small diameter discharges (DN32/1-1/4" threaded and DN50/2" flanged)

- Low installation costs
- Can be installed in areas where the laying of conventional sewer pipes would not be physically possible

6 Temperature monitoring

- Thermal sensors are embedded in the stator windings and can be used to shut the pump off in case of overheating and automatically switch back on once cooled

7 Bearings

- The stainless steel motor shaft is supported by lubricated-for-life, heavy-duty, ball bearings

8 Cable plug

- To facilitate the quick and easy changing or repair of the power cable, the connection between the cable and motor is by means of an integrated 10-pole, quick disconnect, terminal block

9 Adjustable bottom plate

- To counter the effects of wearing and to maintain efficiency, the optimum clearance between the bottom plate and the impeller can easily be restored

Explosion proof

- ATEX (EX II 2 G k Ex d IIB T4), FM (Class 1, Div. 1, Groups C&D), and CSA standards available

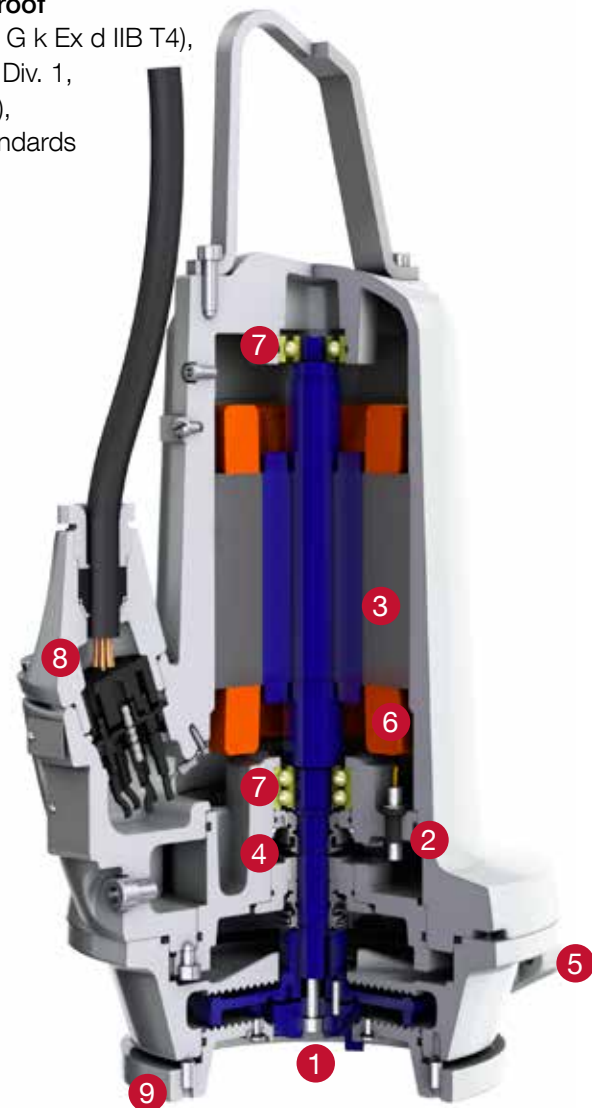

S Series

Sulzer's standard range of submersible grinder pumps, type ABS Piranha S, are equipped with water-tight, fully encapsulated, flood-proof motors. The pump and motor section form a compact unit, providing an economical, yet robust solution without compromising on the reliable design.

1 Piranha cutting system

- A spiral-grooved bottom plate and hardened stainless steel stationary cutting element, combined with a hardened stainless steel lobed rotor cutting element prior to the impeller provide optimum, blockage-free operation

2 Seal leak detection system*

- Advanced warning allows for repair of the pump seal prior to water entering the motor

3 Shaft sealing

- High quality silicon carbide (SiC/SiC) mechanical seal
- Motor-side sealing provided by an oil lubricated lip seal arrangement

4 Small diameter discharge

- Low installation costs
- Can be installed in areas where the laying of conventional sewer pipes would not be physically possible

5 Explosion proof (optional)

- In accordance with FM (Class 1, Div. 1, Groups C&D) and CSA

6 Bearings

- The stainless steel motor shaft is supported by lubricated-for-life, heavy-duty, ball bearings

7 Temperature monitoring

- Thermal sensors are embedded in the stator windings and can be used to shut the pump off in case of overheating and automatically switch back on once cooled

8 Adjustable bottom plate

- To counter the effects of wearing and to maintain efficiency, the optimum clearance between the bottom plate and the impeller can easily be restored

9 Cable plug (non-EX/FM models)*

- To facilitate the quick and easy changing or repair of the power cable, the connection between the cable and motor is by means of an integrated pin-style, Easy-Fit terminal block

Built-in capacitor**

- Does not require a control box

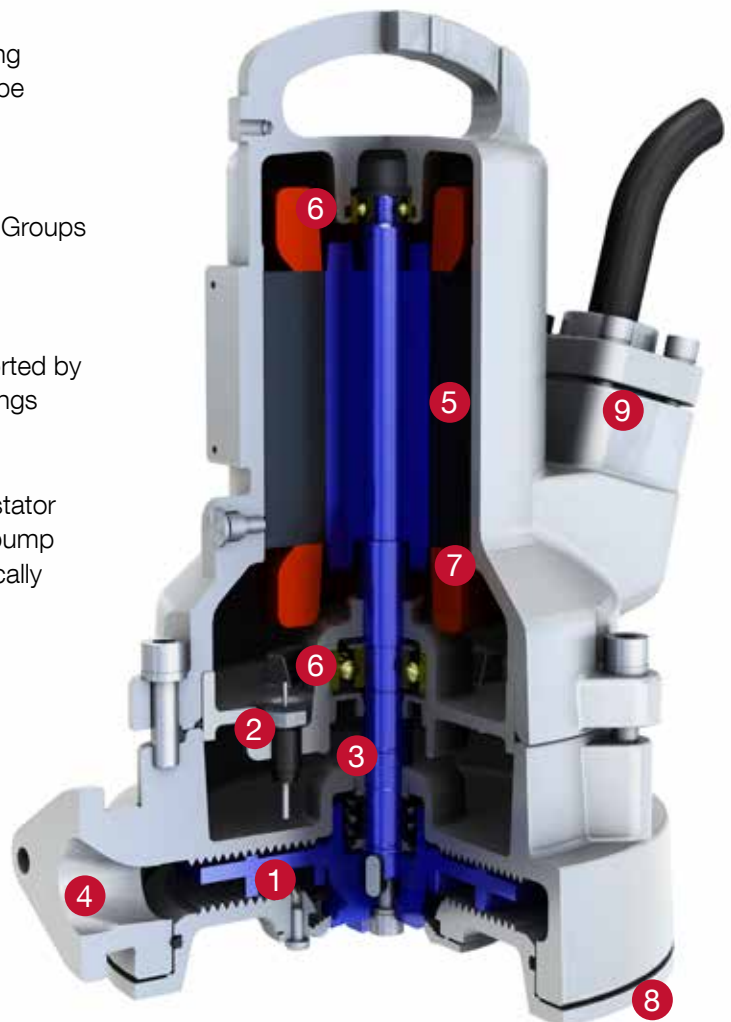

*not available for Piranha 09

** Piranha 09 only

Submersible Grinder Pumps Type ABS Piranha



Operating data

50 Hz	60 Hz
32 to 50 mm	1¼ to 2 in 32 to 50 mm
up to 6 l/s	up to 122 USgpm up to 8 l/s
up to 71 m	up to 265 ft up to 81 m
up to 7 bar	up to 116 psi up to 8 bar
40°C 60°C (short term)	104°F / 40°C 140°F / 60°C (short term)

Performance ranges

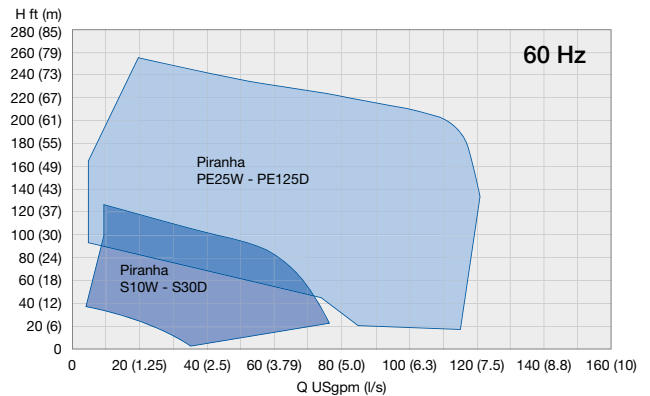
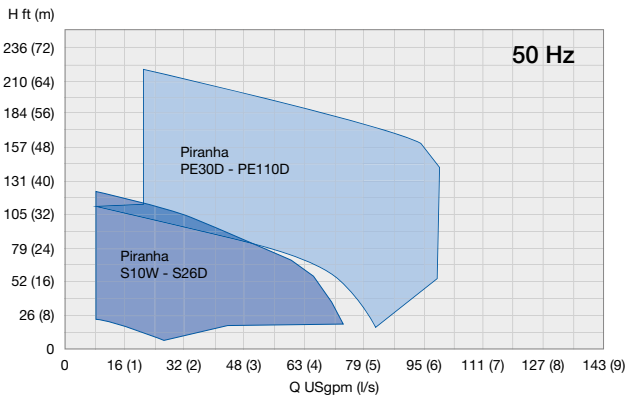

Materials

Pump part	Material
Motor housing, volute, impeller, bottom plate	Cast iron EN-GJL-250 (ASTM A-48, Class 35B)
Rotor shaft	Stainless steel 1.4021 (AISI 420)
Fasteners	Stainless steel 1.4401 (AISI 316)
Mechanical seal	Silicon carbide
Rotating and stationary cutters	Stainless steel 1.4528 (AISI 440B+Co), 58-62 HRC



www.sulzer.com

Netco Pumps & Equipment

E10334 us 3.2016, Copyright © Sulzer Ltd 2016

This brochure is a general presentation. It does not provide any warranty or guarantee of any kind. Please, contact us for a description of the warranties and guarantees offered with our products. Directions for use and safety will be given separately. All information herein is subject to change without notice.