



MUFFIN MONSTER

In-line/Open Channel Grinders





10K series Muffin Monster®

The 10K Series Muffin Monster is a compact grinder, tough on solids in sludge and sewage applications. It fits into areas with limited space requirements while still providing the necessary power for downstream protection. The 10K Series is an ideal, low-cost solution that goes beyond sludge grinding at resource recovery facilities, and fits perfectly into office buildings, apartment complexes, resorts, retail centers and package treatment plants.

30K series Muffin Monster®

Troublesome solids are now easier than ever to reduce with the Muffin Monster dual-shafted grinder. Its slow speed, high-torque design shreds tough solids that typically cause sewer problems. With over 35,000 installations, the proven capabilities of the Muffin Monster is legendary in providing solutions for the ever more stringent operational needs arising throughout the industry.

40K series Muffin Monster®

The 40K Series Muffin Monster excels in wet and dry grinding applications. It's a powerful shredder for large sludge processing systems. It also serves in many industrial applications including fish and beef processing, petroleum, pulp and paper mills, chemical plants, and recycling plants. The proven capabilities of the Muffin Monster are now providing solutions for the ever more stringent operational needs arising throughout the industry.

Muffin Monster sewage grinders are designed to protect pumps and other equipment by grinding down the toughest wastewater solids. Applications including: lift station, sludge lines; septage receiving stations; headworks screenings reduction, prisons and more.

wipes ready™ technology



Wipes Ready™ Cutters*

Achieve the desired 2-Dimensional cutting capabilities to control both the width and length of output, preventing materials from forming long strips and reweaving in the waste stream.

- Cut wipes in 2 directions
- Smaller particle size
- No reweaving

* Patent Pending



Features

Dual Shafted Grinder

- Slow-speed, high torque grinders handle rags, rocks, wood, wipes, clothing, plastics and other debris.
- Capable of grinding a wider variety of solids than single shafted machines, macerators, or chopper pumps.

Compact and Efficient Design

- Adapts to pipelines or channels with little or no modification.
- Custom stainless steel frames allow easy installation in channels, wet wells and pump stations.
- In-line 30K Muffin Monster incorporate an easy to remove cutter cartridge.

Automated Monitoring and Controls

- Auto load sensing and reversals reduce interrupts and optimize the grinder's performance.



Benefits

Equipment Protection

- Protect pumps and other critical equipment from costly clogs and damage from tough solids.

Efficient Treatment Operations

- Grinding separates organic from inorganic materials in the waste stream.
- Organics stay in treatment process and screening are cleaner.

Lower Operating Cost

- Clear pipes and pumps means shorter pump run cycles and lower electrical costs.

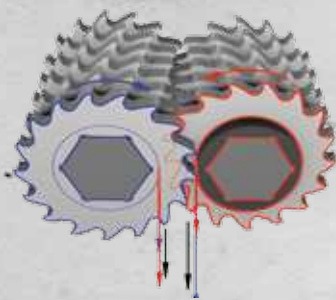

Optimized Cut Control*

Improve cutting by tailoring the speed of the new wipes-ready cutter rotation with optimized cut control.

- **Cutters Stay Clean**
- **Prevents Long Strips**

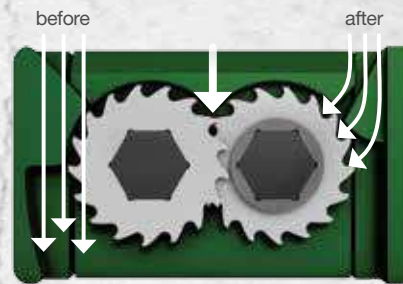

DELTA P* Side Rails

Ensure the capture of all items in the waste stream and drive debris into the cutter stack.

- **Drives Debris into Cutters**
- **Prevents Build Up**
- **Enhances High Flow**



10K Muffin series Monster®

Materials of Construction

Housings: Ductile iron

Cutters: Hardened alloy steel

Shafts: Hardened alloy steel

Mechanical Seals: Tungsten carbide faces

Specifications

2" (50 mm) hex shafts;

Standard 2 HP (1.5 kW) motor; 29:1 reducer

Cutter Size: 4-3/4" (120 mm) diameter cutters

Seal Max Working Pressure: 90 PSI (6 bar)

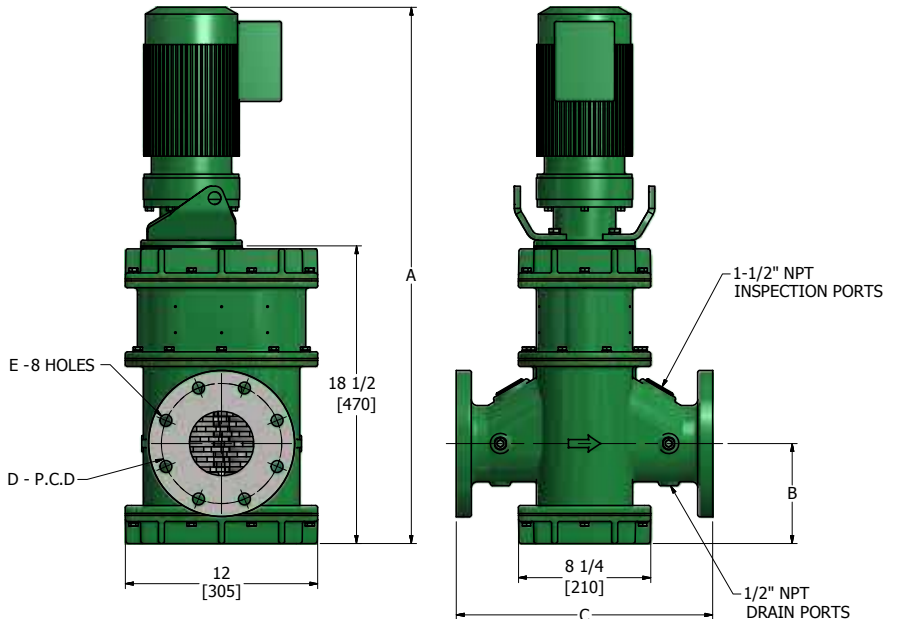

MODEL 10000

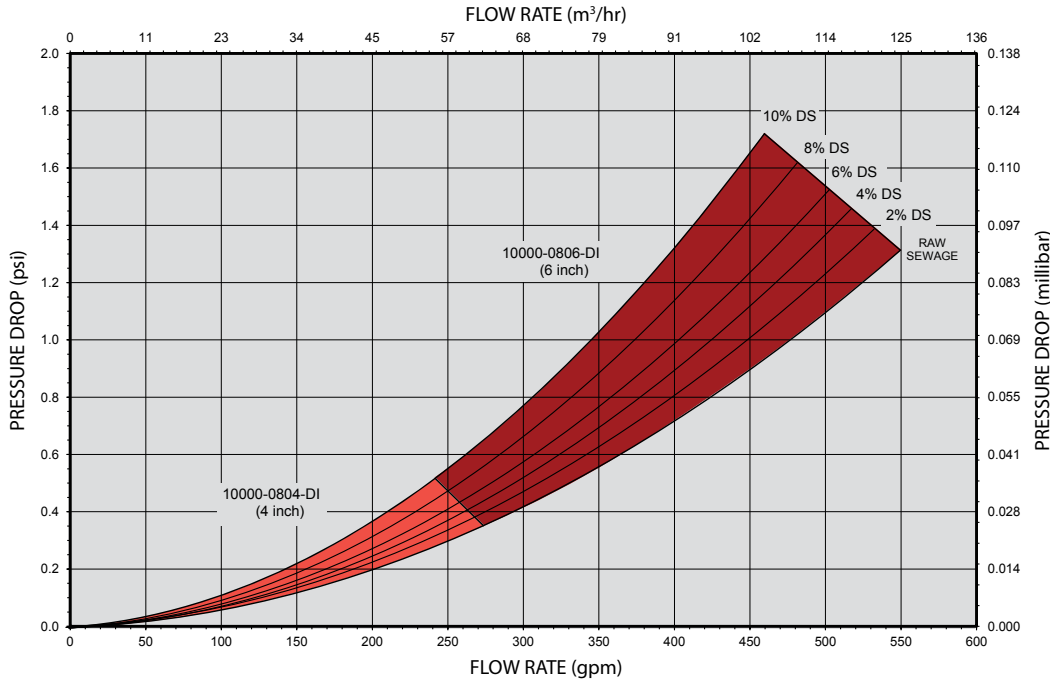

IN-LINE Model	Flow Rate* - gpm (m³/hr)	Pipeline Size - inches (mm)	Pressure Drop - psi (bar)	Standard Dimensions - inches (mm)				Flange Dimensions - inches (mm)		Approximate Net Weight - lbs (kg)
				A - 2 hp (1.5kW)	A - 3 hp (2.2kW)	B	C	D	E	
10000-0804-DI	275 (62)	4 (100)	0.36 (0.03)	33-7/16 (850)	35-7/16 (900)	6-1/4 (158)	16 (406)	7-1/2 (180)	3/4 (19)	303 (137)
10000-0806-DI	550 (125)	6 (150)	1.33 (0.09)	33-7/16 (850)	35-7/16 (900)	7-1/4 (184)	19 (483)	9-1/2 (240)	7/8 (23)	323 (147)

* 0-2% solids • In-Line unit typically installed prior to suction side of pump • Consult factory for analysis of application • Drive dimensions are based on a unit with gear motor.



800.331.2277 | jwce.com | jwce@jwce.com

10K Muffin series Monster®

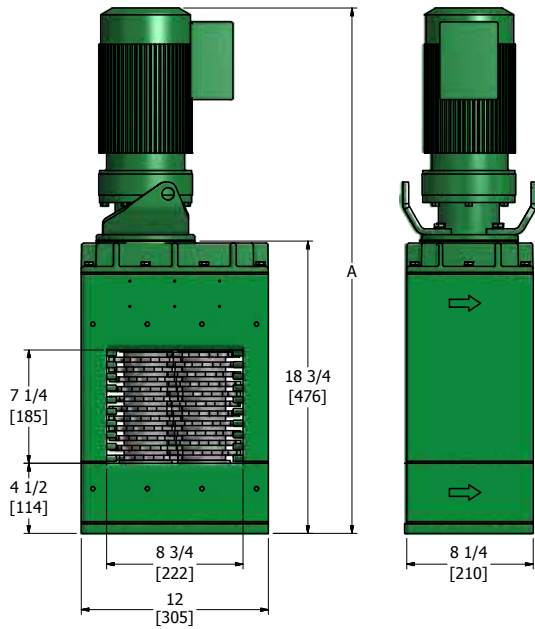

OPTIONS AVAILABLE		
	In-Line	Open Channel
2hp (1.5kW) or 3hp (2.2kW) Motors	■	■
7, 11, 13 Tooth Cutters	■	■
17 Tooth Wipes Ready™ Cutter	■	■
Custom Mounting Frames		■
SS & NEMA 7 Control enclosures	■	■
Alternate Voltage & HP Motors	■	■
Explosion Proof Motors	■	■
Immersible Motors	■	■
Extended Motor Shafts	■	■
ANSI, JIS, JWA, BS & AS Flanges	■	

MODEL 10002

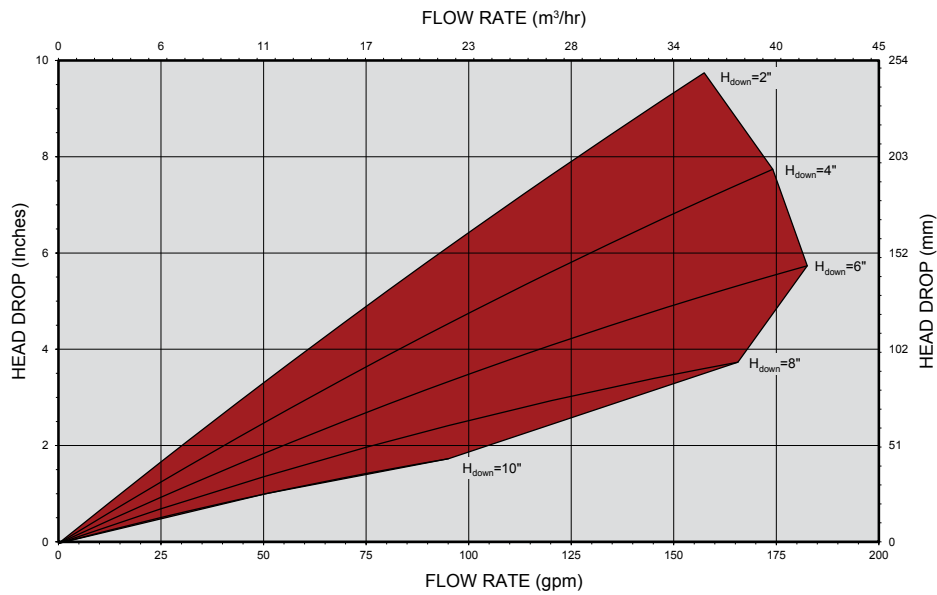

OPEN CHANNEL Model	Flow Rate* - gpm (m³/hr)	Head Drop - inches (mm)	Standard Dimensions - inches (mm)		Approximate Net Weight - lbs (kg)
			A - 2 hp (1.5kW)	A - 3 hp (2.2kW)	
10002-0008-DI	180 (41.4)	5-3/4 (146)	33-11/16 (856)	35-11/16 (906)	338 (153)

- * Flow based on optimum channel conditions. • Consult factory for analysis of application
- Drive dimensions are based on a unit with gear motor.

Santa Ana, CA. USA | 800.331.2277 | jwce.com | jwce@jwce.com

©2016 JWC Environmental. JWC's Santa Ana California facility is registered by UL to ISO9001:2008 #10001313 QM8. JWC International Congleton, UK is registered by OAS to ISO9001:2008 File #A13056. U.S. patents apply: 6,176,443; 6,332,984; 7,073,433; 7,080,650; 7,081,171; 7,086,405; 7,383,842; 7,771,589; 7,854,859; RE37,349E; RE40,422; RE39,948E. U.S. patents pending: 13/628,725; 14/862,238; 14/862,247; 14/862,226; 62/054,656. Additional patents pending. All rights reserved. JWC Environmental is not liable for damages that may result from any information provided in or omitted from this publication, under any circumstances. JWC Environmental reserves the right to make adjustments to this publication at any time, without notices or obligation. Please check the JWC Environmental website (www.jwce.com) for the most up-to-date information or speak to your local rep.



Trust Monster Quality™

30K Muffin series Monster®

Materials of Construction

Housings: Ductile iron

Cutters: Hardened alloy steel

Shafts: Hardened alloy steel

Mechanical Seals: Tungsten carbide faces

Specifications

2" (50 mm) hex shafts;

Standard 3 HP (2.2 kW) motor; 29:1 reducer

Cutter Size: 4-3/4" (120 mm) diameter cutters

Seal Max Working Pressure: 90 PSI (6 bar)

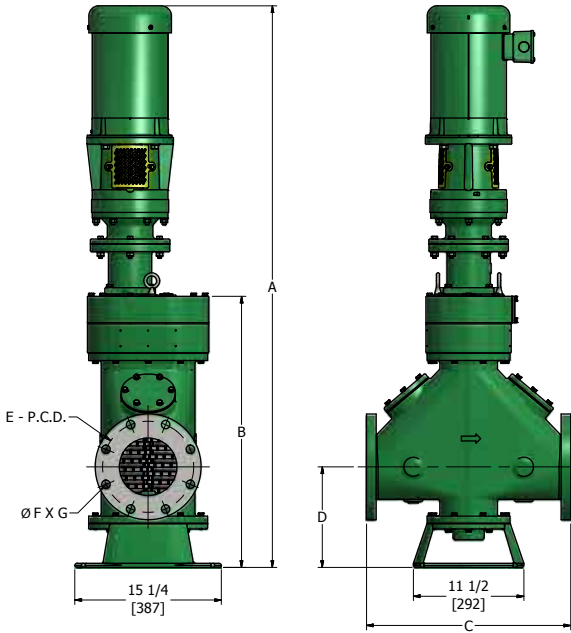

OPTIONS AVAILABLE		
	In-Line	Open Channel
7, 11, 13 Tooth Cutters	■	■
17 Tooth Wipes Ready™ Cutter	■	■
Custom Mounting Frames		■
SS & NEMA 7 Control enclosures	■	■
Solids Scrapers		■
Stainless Steel Feed Hopper		■
Alternate Voltage & HP Motors	■	■
Explosion Proof Motors	■	■
Immersible Motors	■	■
Hydraulic Power Pack	■	■
Extended Motor Shafts	■	■
ANSI, JIS, JWA, BS & AS Flanges	■	

MODEL 30004T

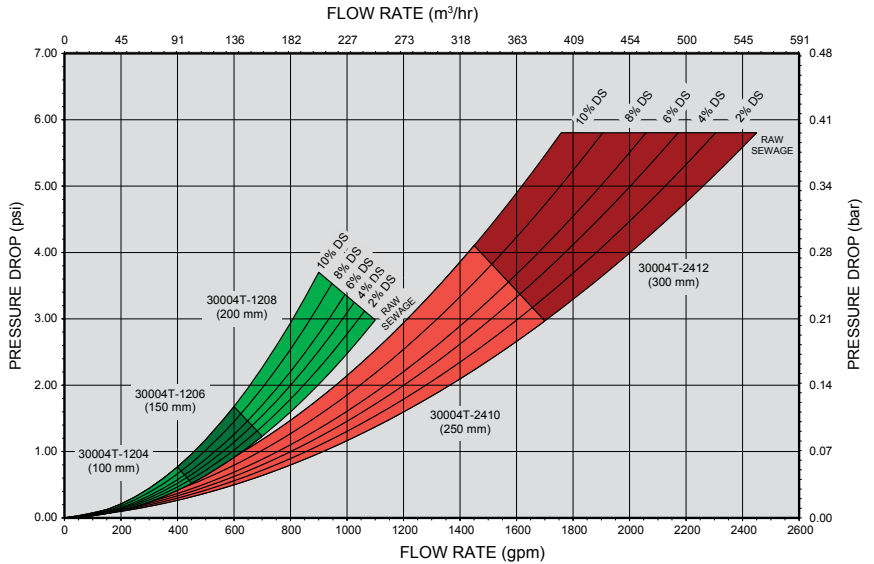

IN-LINE Model	Flow Rate - gpm (m³/hr)	Pipeline Size - inches (mm)	Pressure Drop - psi (bar)	Standard Dimensions - inches (mm)				Flange Dimensions - inches (mm)			Approximate Net Weight - lbs (kg)
				A	B	C	D	E	F	G	
30004T-1204	450 (102)	4 (100)	0.52 (0.04)	58-1/4 (1480)	28-1/4 (718)	19-1/4 (483)	9-3/8 (238)	7-1/2 (191)	3/4 (19)	8	562 (255)
30004T-1206	700 (159)	6 (150)	1.23 (0.08)	58-1/4 (1480)	28-1/4 (718)	21-1/4 (534)	10-3/8 (264)	9-1/2 (241)	7/8 (22)	8	559 (254)
30004T-1208	1100 (250)	8 (200)	3.00 (0.21)	58-1/4 (1480)	28-1/4 (718)	23-1/4 (584)	11-1/4 (238)	11-3/4 (286)	7/8 (22)	8	568 (258)
30004T-2410	1700 (386)	10 (250)	2.97 (0.20)	69-3/4 (1772)	39-3/4 (1010)	27-1/4 (686)	12-5/16 (313)	14-1/4 (362)	1 (25)	12	789 (358)
30004T-2412	2450 (556)	12 (300)	5.80 (0.40)	69-3/4 (1772)	39-3/4 (1010)	31-1/4 (787)	13-1/4 (337)	17 (431)	1 (25)	12	809 (367)

In-Line unit typically installed prior to suction side of pump. • Consult factory for analysis of application.

• Drive dimensions are a maximum based on a unit with a 3 HP (2.2 kW) drive.



30K Muffin series Monster®

MODEL 30005

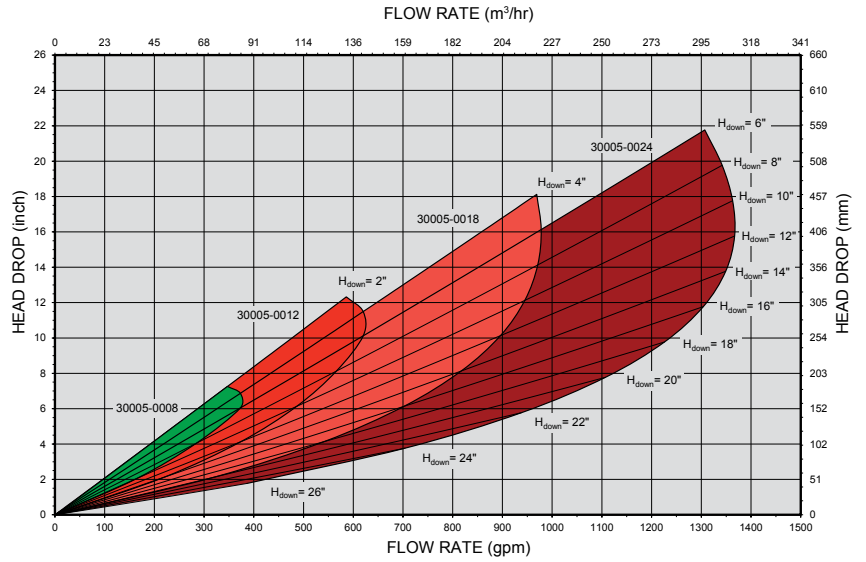
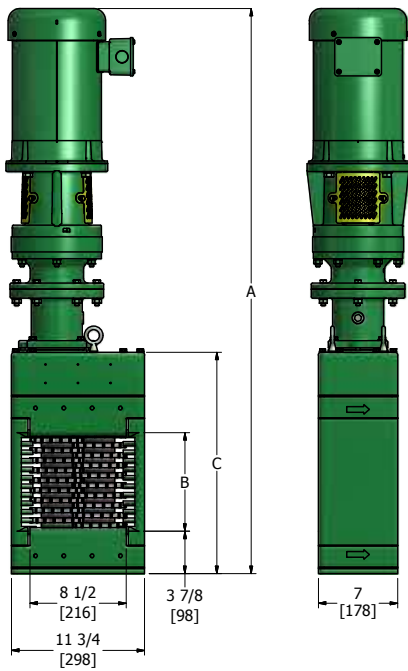

MODEL 30005

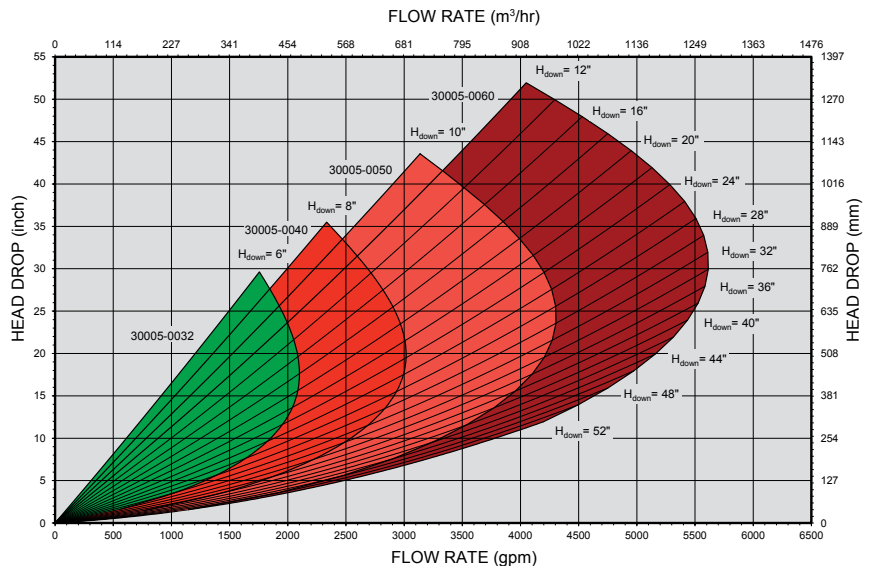

OPEN CHANNEL Model	Flow Rate - gpm (m³/hr)	Head Drop - inches (mm)	Standard Dimensions - inches (mm)			Approximate Net Weight - lbs (kg)
			A	B	C	
30005-0008	370 (84)	7 (178)	49-1/2 (1257)	8 (203)	19-1/2 (495)	370 (168)
30005-0012	620 (141)	11-1/2 (290)	53-5/8 (1362)	12 (305)	23-5/8 (600)	410 (186)
30005-0018	980 (223)	16 (405)	59-1/2 (1511)	18 (457)	29-1/2 (749)	465 (211)
30005-0024	1370 (311)	16 (405)	65-1/4 (1657)	24 (609)	35-1/4 (895)	520 (236)
30005-0032	2100 (477)	17-1/2 (445)	73 (1854)	32 (813)	43 (1092)	580 (263)
30005-0040	3020 (686)	19-1/2 (495)	81 (2057)	40 (1016)	51 (1295)	650 (295)
30005-0050	4310 (979)	23-1/2 (595)	90-7/8 (2308)	50 (1270)	60-7/8 (1546)	740 (336)
30005-0060	5620 (1277)	30 (760)	101-3/8 (2575)	60 (1524)	71-3/8 (1813)	845 (383)

* Flow based on optimum channel conditions. • Consult factory for analysis of application.
 • Drive dimensions are a maximum based on a unit with a 182T motor frame. • Extended drive shafts are available on request.

Santa Ana, CA, USA | 800.331.2277 | jwce.com | jwce@jwce.com

©2016 JWC Environmental. JWC's Santa Ana California facility is registered by UL to ISO9001:2008 #10001313 QM8. JWC International Congleton, UK is registered by OAS to ISO9001:2008 File #A13056. U.S. patents apply: 6,176,443; 6,332,984; 7,073,433; 7,080,650; 7,081,171; 7,086,405; 7,383,842; 7,771,589; 7,854,859; RE37,349E; RE40,422; RE39,948E. U.S. patents pending: 13/628,725; 14/862,238; 14/862,247; 14/862,226; 62/054,656. Additional patents pending. All rights reserved. JWC Environmental is not liable for damages that may result from any information provided in or omitted from this publication, under any circumstances. JWC Environmental reserves the right to make adjustments to this publication at any time, without notices or obligation. Please check the JWC Environmental website (www.jwce.com) for the most up-to-date information or speak to your local rep.



40K Muffin series Monster®

Materials of Construction

Housings: Ductile iron

Cutters: Hardened alloy steel

Shafts: Hardened alloy steel

Mechanical Seals: Tungsten carbide faces

Specifications

2-1/2" (64 mm) hex shafts;

Standard 10 HP (7.5 kW) motor; 43:1 reducer

Cutter Size: 7-1/2" (191 mm) diameter cutters

Seal Max Working Pressure: 90 PSI (6 bar)

MODEL 40002-Inline
FLOW RATE (m³/hr)

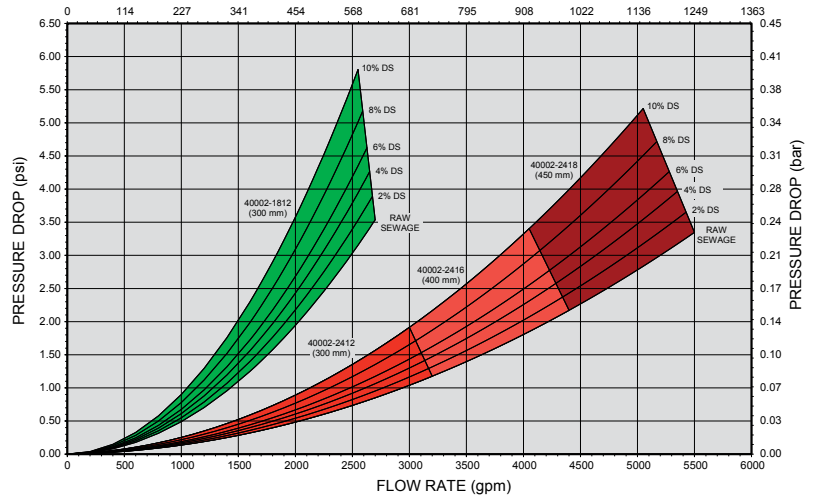

MODEL 40002-Inline
FLOW RATE (m³/hr)

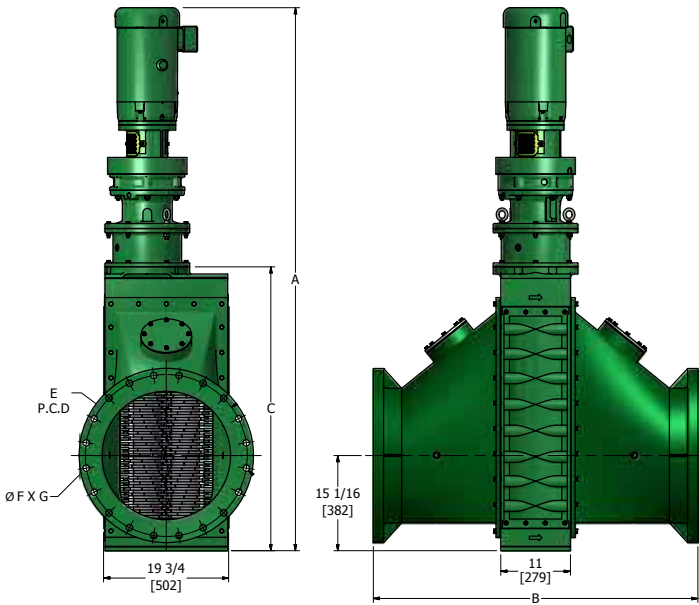
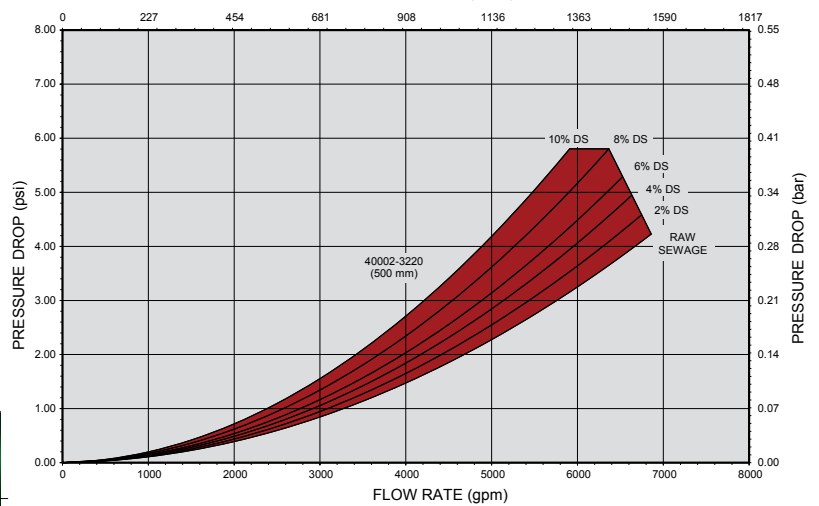

IN-LINE Model	Flow Rate - gpm (m ³ /hr)	Pipeline Size - inches (mm)	Pressure Drop - psi (bar)	Standard Dimensions - inches (mm)			Flange Dimensions - inches (mm)			Approximate Net Weight - lbs (kg)
				A	B	C	E	F	G	
40002-1812	2700 (612)	12 (300)	3.5 (0.24)	69-5/8 (1768)	35-1/4 (895)	30-1/4 (768)	17 (254)	1 (25)	12	1520 (690)
40002-2412	3200 (727)	12 (300)	1.2 (0.08)	76-5/8 (1946)	35-1/4 (895)	37-1/4 (946)	17 (254)	1 (25)	12	1775 (805)
40002-2416	4400 (999)	16 (400)	2.2 (0.15)	76-5/8 (1946)	43-1/4 (1099)	37-1/4 (946)	21-1/4 (539)	1-1/8 (29)	16	1895 (860)
40002-2418	5500 (1249)	18 (450)	3.4 (0.23)	76-5/8 (1946)	47-1/4 (1200)	37-1/4 (946)	22-3/4 (578)	1-1/4 (32)	20	2095 (950)
40002-3220	6860 (1558)	20 (500)	4.2 (0.29)	83-1/4 (2115)	51-1/4 (1301)	43-7/8 (1114)	25 (635)	1-1/4 (32)	20	2610 (1184)

In-Line unit typically installed prior to suction side of pump. • Consult factory for analysis of application.

• Drive dimensions are a maximum based on a unit with a 10 HP (7.5 kW) drive.



40K Muffin series Monster®

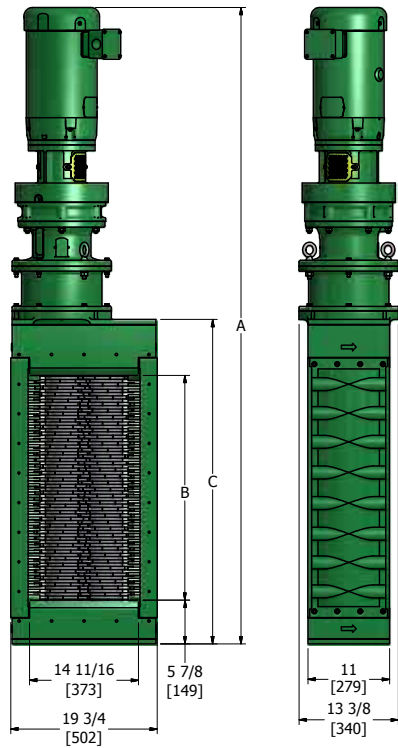

OPTIONS AVAILABLE

	In-Line	Open Channel
7, 11, 23 Tooth Cutters	■	■
Stainless Steel Cutters	■	■
Custom Mounting Frames		■
SS & NEMA 7 Control enclosures	■	■
Solids Scrapers		■
Nickel Plated Housing		■
Stainless Steel Feed Hopper		■
Alternate Voltage & HP Motors	■	■
Explosion Proof Motors	■	■
Immersible Motors	■	■
Hydraulic Power Pack	■	■
Extended Motor Shafts	■	■
ANSI, JIS, JWA, BS & AS Flanges	■	

MODEL 40002-Open Channel

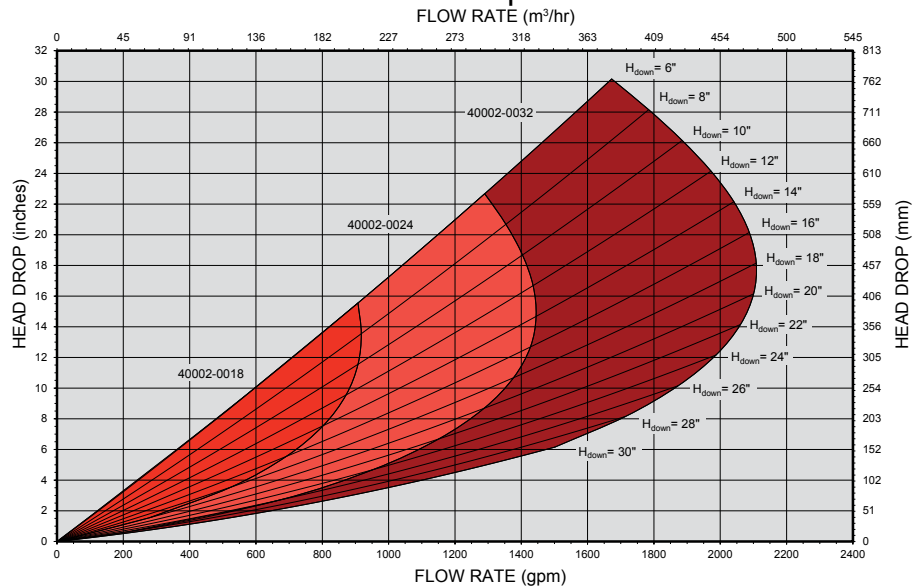

OPEN CHANNEL Model	Flow Rate - gpm (m³/hr)	Head Drop - inches (mm)	Standard Dimensions - inches (mm)			Approximate Net Weight - lbs (kg)
			A	B	C	
40002-0018	915 (207)	8 (203)	69-5/8 (1768)	18 (457)	30-1/4 (768)	1175 (533)
40002-0024	1440 (327)	16 (406)	76-5/8 (1946)	24 (610)	37-1/4 (946)	1365 (619)
40002-0032	2100 (477)	18 (457)	83-1/4 (2115)	32 (813)	43-7/8 (1114)	1560 (708)

* Flow based on optimum channel conditions. • Consult factory for analysis of application.

• Drive dimensions are a maximum based on a unit with a 10 HP (7.5 kW) drive. • Extended drive shafts are available on request.

Santa Ana, CA. USA | 800.331.2277 | jwce.com | jwce@jwce.com

©2016 JWC Environmental. JWC's Santa Ana California facility is registered by UL to ISO9001:2008 #10001313 QM8. JWC International Congleton, UK is registered by OAS to ISO9001:2008 File #A13056. U.S. patents apply: 6,176,443; 6,332,984; 7,073,433; 7,080,650; 7,081,171; 7,086,405; 7,383,842; 7,771,589; 7,854,859; RE37,349E; RE40,422; RE39,948E. U.S. patents pending: 13/628,725; 14/862,238; 14/862,247; 14/862,226; 62/054,656. Additional patents pending. All rights reserved. JWC Environmental is not liable for damages that may result from any information provided in or omitted from this publication, under any circumstances. JWC Environmental reserves the right to make adjustments to this publication at any time, without notices or obligation. Please check the JWC Environmental website (www.jwce.com) for the most up-to-date information or speak to your local rep.



Trust Monster Quality™

Muffin Monster[®]

options



7-Tooth:
Pump Stations or Prisons



11-Tooth:
Wastewater, Sludge
or Scum



13-Tooth:
Heat-exchanger or
Centrifuge Protection



17-Tooth: *
Rags, Stringy Materials

Cutters

- 7, 11, 13, 17 and 23 tooth options.
- Special Cutter designs for unique needs.
- Optional stainless steel cutters.
- ★ 17-Tooth Serrated Wipes Ready™ Cutter.



Electric Motor



Exclusive: JWC Designed
Immersible Motor
(NEMA-6P)



Hydraulic Drive

Motors

- TEFC: Totally enclosed fan cooled electric.
- XPFC: Explosion proof fan cooled electric.
- XPNV: Exclusive electric immersible.
- Hydraulic Drives available in: 2, 3, 5, 10 HP (2.2, 3.7, 7.5 kW).

Hydraulic Power Packs

- Available in: 5, 10, 15 HP (3.7, 7.5, 11 kW).



Custom Control Configurations



Model PC2200 Standard Enclosure

Smart Controller

- Load sensing control system automatically reverse to clear jams.
- Standard: NEMA-4X FRP enclosure with 3-position switch and status indicators.
- Optional: NEMA 4X stainless steel or NEMA 7 enclosures.
- Customized control configurations for any installation.
- UL registered.



Muffin Monster[®] options



Custom Wall Frames

Custom Wall Frames

- Stainless steel guide frames attach to pump station to make installation easier.
- Frame is customized to fit each site and includes: guide rails; grinder support base; overflow bar racks and more.



Custom Channel Frame

Custom Channel Frames

- Adapt grinders to fit any channel.
- Guide rails for easy installation and maintenance.
- Stainless Steel construction.

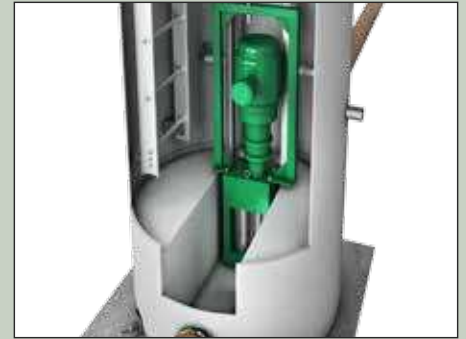

Pre-fab Muffin Monster Manhole

Muffin Monster Manhole

- Pre-fabricated fiberglass reinforced manhole with grinder.
- Custom Depth.
- Hinged cover or H-20 traffic rated top.



Scrapers (optional)

Scrapers

- Integrated steel scrapers increase throughput and help cutters clean-out faster.
- Improves performance of hopper fed applications.



Extended Motor Shaft

Extended Motor Shaft

- Places motor above highest water level. Available in 1' (305 mm) increments. Maximum: 15' (4570 mm).



Custom Hoppers

Hoppers

- Custom made to fit application.
- 304 or 316 stainless steel.



Santa Ana, CA. USA | 800.331.2277 | jwce.com | jwce@jwce.com

© 2016 JWC Environmental. U.S. Environmental Protection Agency registered by U.S. Environmental Protection Agency. All rights reserved. JWC Environmental is a registered trademark of JWC Environmental. All other trademarks are the property of their respective owners. JWC Environmental is not responsible for any damage or injury to property or equipment caused by the use of this product. For more information, please visit our website at www.jwce.com or call 800.331.2277. JWC Environmental is not responsible for any damage or injury to property or equipment caused by the use of this product. For more information, please visit our website at www.jwce.com or call 800.331.2277.



Trust Monster Quality™



Since its founding in 1973, JWC Environmental has become a world leader in solids reduction and removal for the wastewater industry with its Muffin Monster grinders and Monster Separation Systems. JWC also solves challenging size reduction and processing problems in commercial and industrial applications through its Monster Industrial division. JWC Environmental is headquartered in Santa Ana, California, and has a global network of representatives, distributors and regional service centers to provide customer support.

For more information, visit JWC Environmental at www.jwce.com.



JWC
Environmental®

Trust Monster Quality™

Headquarters
2850 S. Red Hill Ave., Suite 125
Santa Ana, CA 92705 USA
toll free: 800.331.2277
phone: 949.833.3888
fax: 949.833.8858
email: jwce@jwce.com

www.jwce.com



MONSTER
INDUSTRIAL

IPEC®

FRC®