

**FISH TRANSPORTATION EQUIPMENT**  
**Immersible Fish Pumps**

*For Fish Transfer Applications*

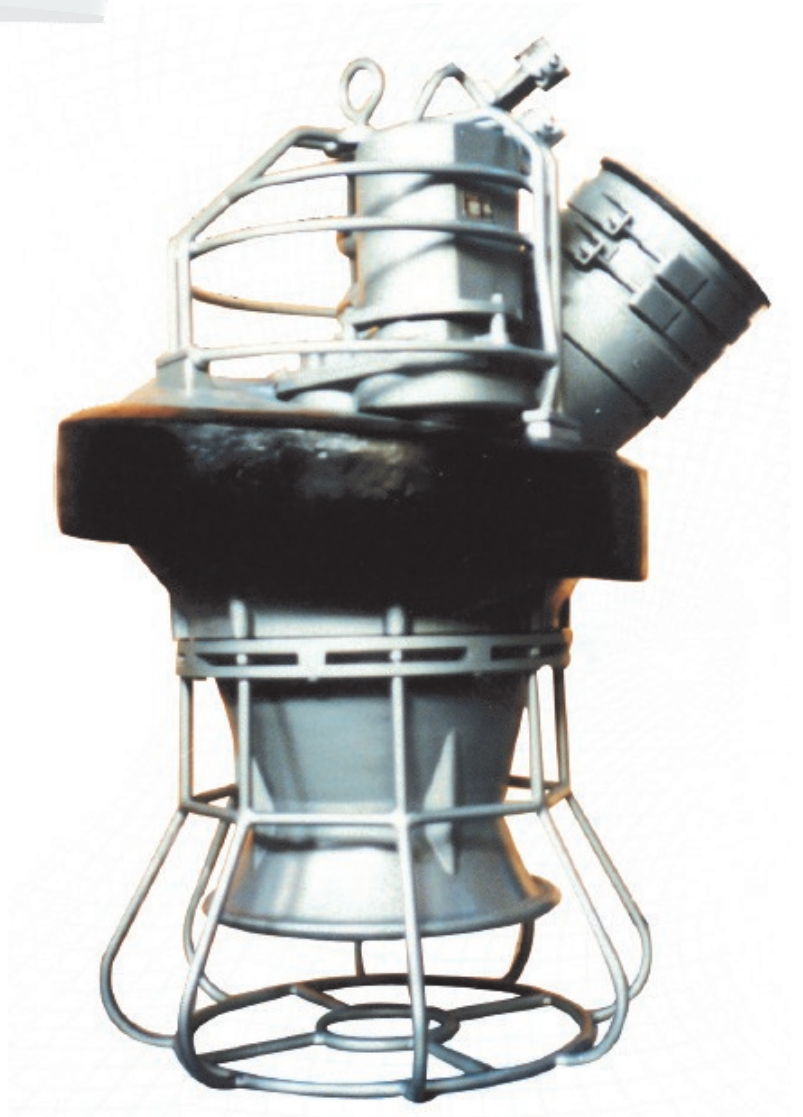



## MATERIAL SPECIFICATIONS

Designed specifically for the fishing industry, Hidrostal's unique hydraulic concepts assure efficient and damage-free fish transportation. Utilising the Hidrostal originated enclosed screw centrifugal impeller with large open passage, this completely immersible pump unloads fish from the net to your hold, damage-free. Fishing fleets have found that the Hidrostal pump has helped them achieve increased profits due to a larger, damage-free catch.

## EASY INSTALLATION

Pump can be tied into existing hydraulic system. Pump is lowered by boom into the fish net and can be placed wherever it is needed to empty the net.

## DEPENDABLE OPERATION

New design concepts assure maintenance free service.

## CAPACITIES TO MEET YOUR REQUIREMENT

A wide range of sizes are available to meet individual industry requirements for volume and type of fish to be handled.

Model I18V, Hidrostal's largest unit, can pump 520 tonnes/hour of fish and water at 22 feet of head.

Total range is available to move high volumes of fish quickly and without damage.

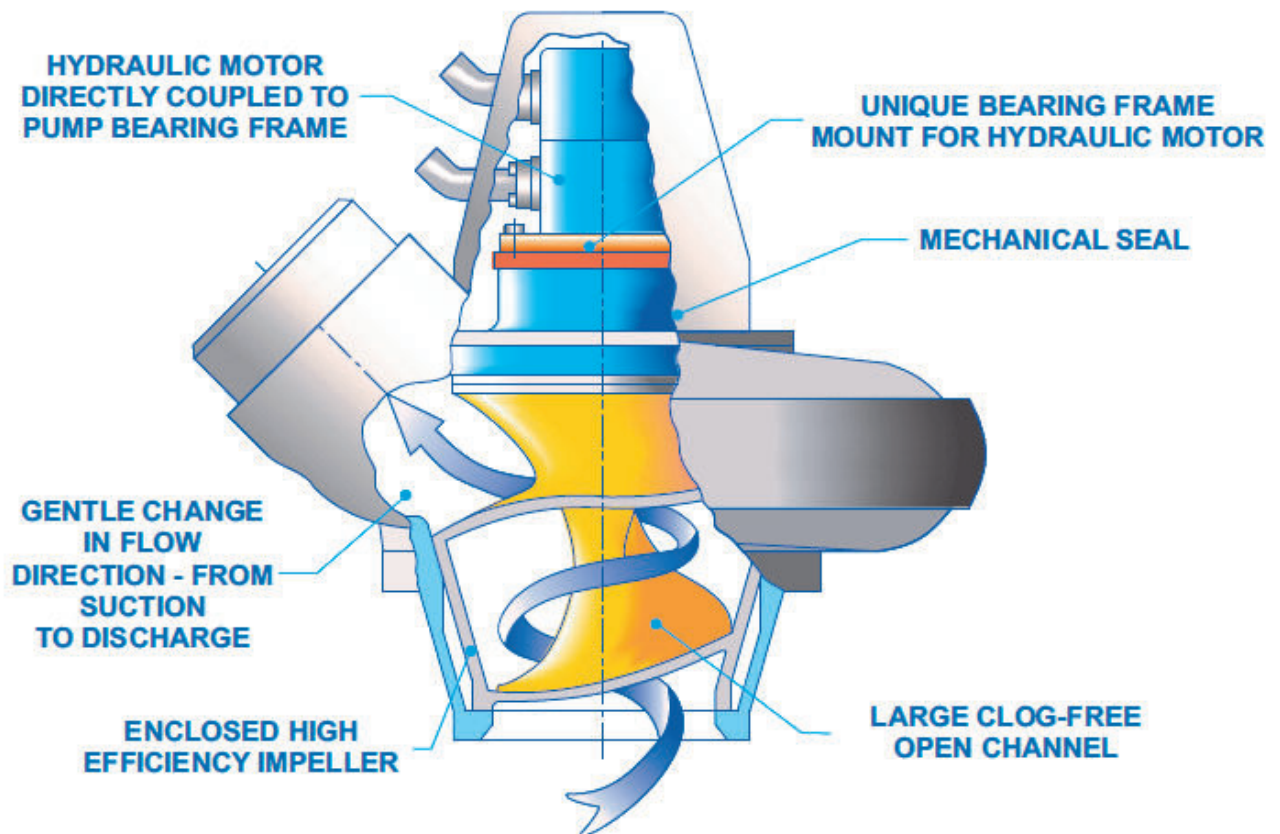



## MATERIAL SPECIFICATIONS

### CASING

Axial suction and radial discharge designed to allow passage of fish without damage. Casing is Alcoa 356 Aluminium, with discharge fitting grooved for clamping lightweight discharge hose directly to the pump.

### IMPELLER

Enclosed screw centrifugal, single open channel uniform acceleration design. Cast in Alcoa 356 Aluminium.

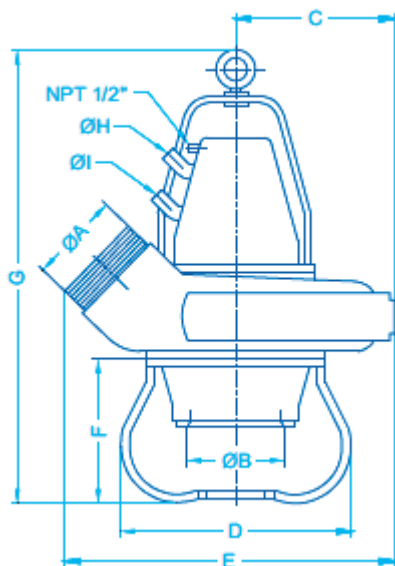

### BEARING FRAME

Heavy duty shaft of AISI 416 steel is supported by two grease lubricated bearings designed to carry both radial and axial loads for 15,000 hours.

### SEAL CHAMBER

Oil lubricated mechanical seal.

### CASING BUMPER

Sea water resistant, high impact design rubber surrounds casing to protect pump from impact.

### SUCTION STRAINER

Galvanized bar design to prevent net from being pulled into pump suction.

### LIFTING MANTLE

Galvanized bar design with lifting eye.

### MOTOR

Vickers and Sai hydraulic motor coupled directly to pump bearing frame which provides overload protection and assures long motor life. Motor is protected by an aluminium hood. Adapters are provided for easy connection to hydraulic lines.

PUMP MODEL	VICKERS MOTOR MODEL	DIMENSION DATA										
		INCH				MILLIMETERS					WEIGHT	
		A	B	H	I	C	D	E	F	G	KILO	POUND
E10V-SH	25M 65	10"	10"	1"	1"	350	420	800	280	850	136	299
F12V-SH	36M 115	12"	12"	1"	1"	400	540	950	360	1200	210	462
H12V-SS	46M 185	12"	12"	1.14"	1.14"	540	787	1220	546	1630	438	965
H12V-SS	51M 300	12"	12"	1.14"	1.14"	540	787	1220	546	1630	474	1044
H14V-SS	51M 300	14"	14"	1.14"	1.14"	540	787	1220	546	1630	477	1051
H16V-SH	51M 300	16"	16"	1.12"	1.12"	540	787	1220	546	1630	481	1060
I18V-SS-G1	51M 300	18"	18"	1.12"	1.12"	635	1080	1405	750	1970	751	1652
I18V-SS-G2	51M 300	18"	18"	1.12"	1.12"	635	1080	1405	750	1970	751	1652



## EXCLUSIVE FEATURES

Large, smooth open channel with no abrupt change of direction allows the fish to move through the pump from suction to discharge, without damage.

Open channel design allows passage of large fish and also provides continuous non-clog operation to minimise down-time.

Enclosed design impeller prevents fish from contacting suction cover, preventing damage to both small and large fish.

High efficiency design reduces energy consumption and lowers the cost of transporting fish.

Unique bearing frame mount for hydraulic motor assures longer, trouble-free motor life than competitive designs, that depend entirely on motor bearings for overload protection.

## CUSTOMER BENEFITS

Larger size fish can be handled by Hidrostal when using pump sizes comparable to competition. This capability is most important for the process of canning or freezing of fish.

Immersible design eliminates need for priming.

When lowered into the net, Hidrostal's high suction capability allows it to clean the net completely.

Lightweight aluminium casing and impeller make handling easy.

No heavy suction hose required. Lightweight discharge hose delivers the fish to the boat hold.

SELECTION DATA									
PUMP MODEL	VICKERS MOTOR MODEL	CAPACITY TON/HOUR DRIED FISH 50/50 SARDINES *	FREE PASSAGE INCH	TDH		HP CONSUMPTION 50 / 50 *	PUMP RPM *	OIL REQUIREMENT	
				METER *	FEET *			GPM *	PSI *
E10V-SH	25M 65	207	4	5.8	19	21.3	1200	24.5	1700
F12V-SH	36M 115	345	5.25	6.5	21.3	38.6	1000	38	2190
F12V-SS	46M 185	425	6.25	6.5	21.3	48.6	740	45	2250
H12V-SS	51M 300	482	6.25	7.5	24.6	62.2	800	75	1660
H14V-SS	51M 300	540	6.25	9.5	31.2	87	900	87	2100
H16V-SH	51M 300	675	7	9.5	31.2	107	985	96	2250
I18V-SS-G1	51M 300	855	9	8	26.2	116	625	120	1850
I18V-SS-G2	51M 300	954	9	10	32.8	140	700	140	2000

\* For other operating points consult specific curve