



Stainless Steel Pumps

Model 3LS 316 S/S Centrifugal Pumps (2 pole)

To DIN 24255



Stub shaft design

Uses IEC standard motors



Standard with high quality Silicon Carbide mechanical seal

All the hydraulic and wetted components are manufactured in 316 Stainless Steel

This series of stainless steel pumps feature a unique one piece volute casing that is produced using an advanced computer controlled Plasma stamping system that ensures total quality control during manufacture. With the smooth surfaces of stamped stainless steel, this results in consistent high standard products, of superior quality and high efficiency. (Cast casing on 65-250 & 80 models)

The back pull-out construction permits the disassembly and overhaul of the impeller, mechanical seal and motor without removal of the suction or discharge piping, or pump casing.

The centre line discharge and foot support under the casing ensure maximum resistance to misalignment and distortion from pipe loads.



Precision cast casing on 65-250 & 80 models

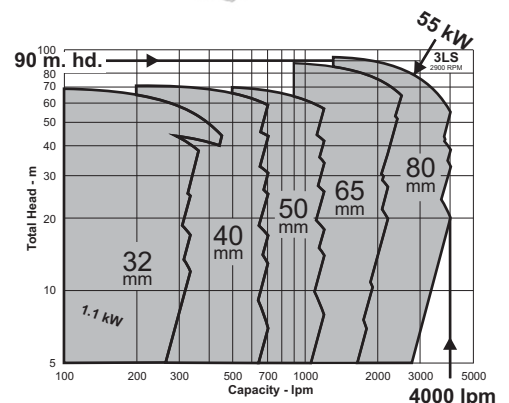

Available as pump end kit (without motor)

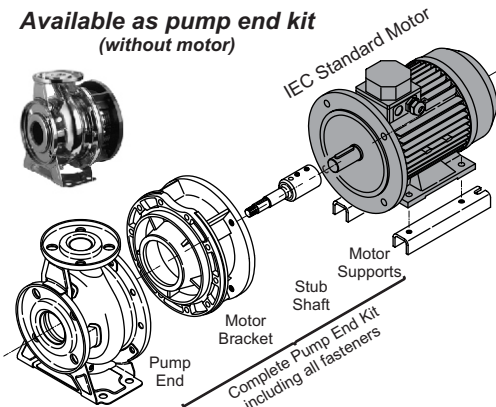

Standard IEC motors used, allowing for single phase, special enclosure, or specific brand motors to be fitted.

Specifications

- End suction centrifugal pump with closed impeller
- Maximum working pressure: 10 bar
- Liquid temperature: -10 °C to +110 °C

Materials

- Pump casing: 316 Stainless Steel
- Impeller: 316 Stainless Steel
- Casing cover: 316 Stainless Steel
- Shaft: 316 Stainless Steel (wetted part)
- Motor bracket: Cast Iron
- Mechanical seal: SiC/SiC/Viton

Motor Data

- IEC standard 2 pole 50 Hz motors
- Normally fitted with WEG motors
- 3 Phase, TEFC, IP55 or above, Class F or above

Range

- 32 to 80 mm Ø discharge
- 1.1 to 55 kW - 3 Phase

Supply

- Available complete with motor or as a pump end kit without motor

Options

- Single phase motors (up to 3.0 kW)
- Other motor brands, types, etc. on request

Accessories

- Companion flange kits.

- Over 40 model sizes
- 32 mm to 80 mm discharge
- 1.1 to 55 kW motor power
- Flows to 4000 lpm
- Heads to 90 metres

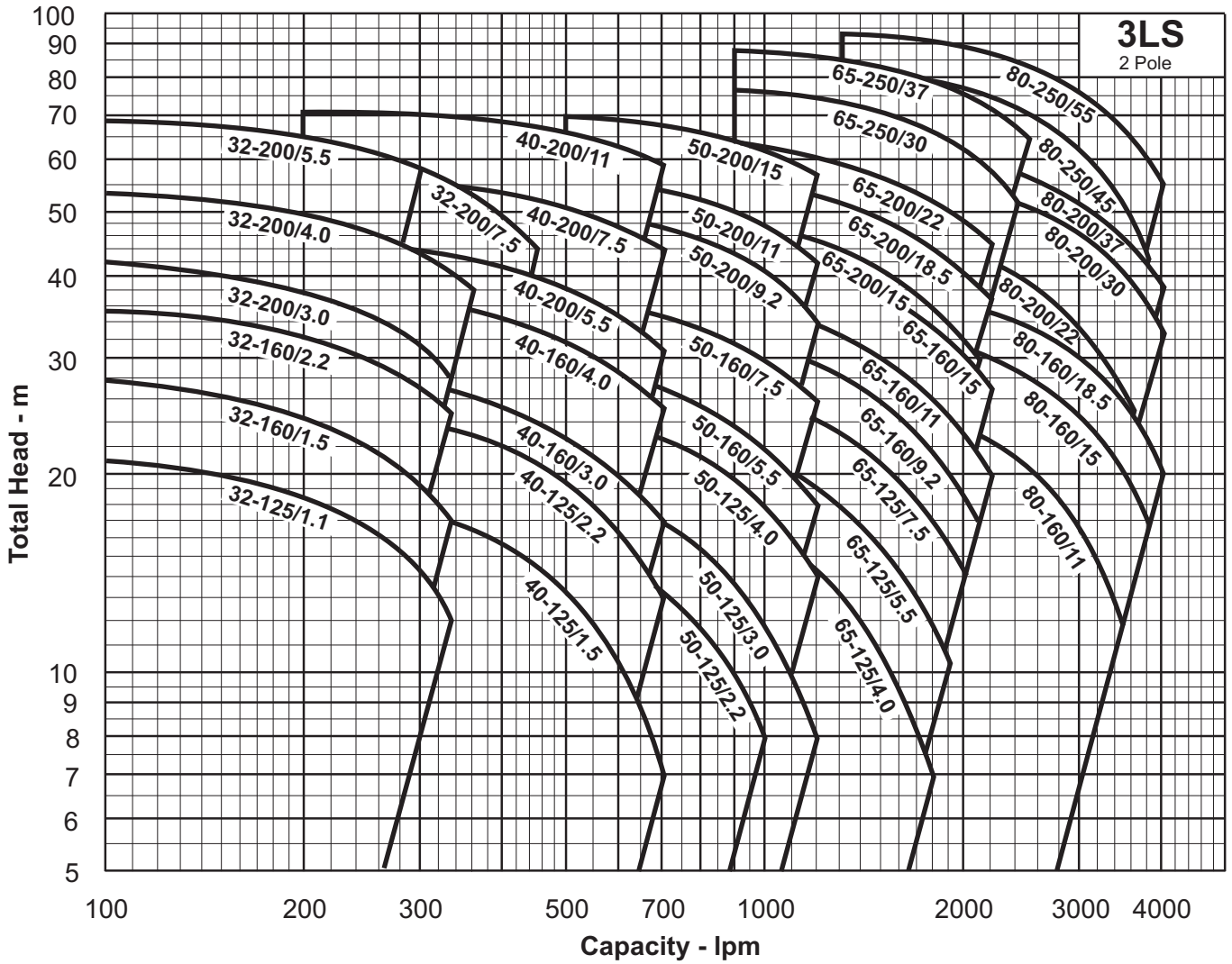

Model Code 3LS 40 - 200 / 7.5 M

- M = Single Phase
- Motor Size kW
- Nominal Impeller Diameter mm
- Discharge Size Ø mm
- Model; 3LS with motor; 3LSF without motor (kit)

Synchronous Speed: **3000 rpm**

Water temp: **20 °C**

Applicable standard of test: **ISO 2458 Class C**

Configuration

3LS pumps use IEC standard motors. 3 phase WEG cast iron motors are generally fitted as standard, but single phase, specific brands, special enclosures, etc. can also be supplied. The requirements for frame size and mounting are in the dimension table. Note that B5 = Flange mount; B35 = Foot & Flange mount.

The style of motor support varies depending on model and motor size, as shown in the figures below and referred to in the dimension table.

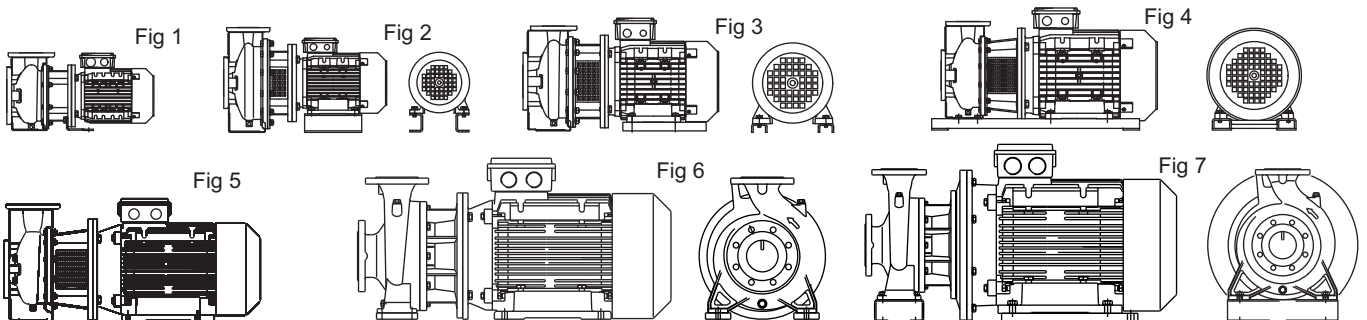

Dimensions - with cast iron W22 WEG motors (E3)

Model **3LS**

Units: mm unless otherwise specified

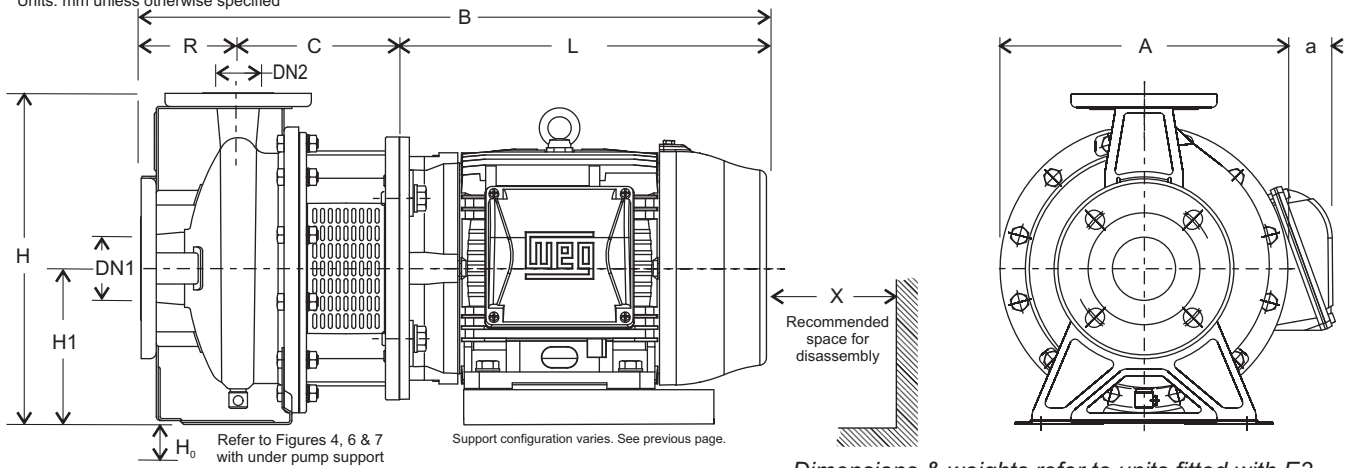

Refer to Figures 4, 6 & 7 with under pump support
Support configuration varies. See previous page.

Dimensions & weights refer to units fitted with E3 high efficiency 3 Phase cast iron WEG W22 motors

* FLC = Motor full load current (A) @ 400 V

DN2 x DN1	Pump Model (...../kW)	Motor details				Dimensions (mm)											Weight (kg)		
		FLC*	Frame	Mount	Config.	H1	H	H ₀	R	C	L	B	A	a	X	Pump End	Motor	Total	
32 mm x 50 mm	3LS 32-125/1.1	2.29	80	B5	Fig 1	112	252	-	80	118	236	434	213	33	110	13	15	28	
	3LS 32-160/1.5	3.02	90S	B5	Fig 1	132	292	-	80	130	254	464	254	30	110	17	19	36	
	3LS 32-160/2.2	4.36	90L	B5	Fig 1	132	292	-	80	130	279	489	254	30	110	17	24	41	
	3LS 32-200/3.0	5.68	100L	B35	Fig 2	160	340	-	80	142	316	538	296	19	110	24	32	54	
	3LS 32-200/4.0	7.49	112M	B35	Fig 2	160	340	-	80	142	333	555	296	44	110	24	41	65	
	3LS 32-200/5.5	10.1	132S	B35	Fig 3	160	340	-	80	165	372	617	296	70	110	28	65	93	
40 mm x 65 mm	3LS 32-200/7.5	13.8	132S	B35	Fig 3	160	340	-	80	165	372	617	296	70	110	28	69	97	
	3LS 40-125/1.5	3.02	90S	B5	Fig 1	112	252	-	80	130	254	464	213	51	115	15	19	34	
	3LS 40-125/2.2	4.36	90L	B5	Fig 1	112	252	-	80	130	279	489	213	51	115	15	24	39	
	3LS 40-160/3.0	5.68	100L	B35	Fig 3	132	292	-	80	142	316	538	254	40	115	20	32	52	
	3LS 40-160/4.0	7.49	112M	B35	Fig 3	132	292	-	80	142	333	555	254	65	115	20	41	61	
	3LS 40-200/5.5	10.1	132S	B35	Fig 3	160	340	-	100	165	372	637	296	70	115	28	65	93	
50 mm x 65 mm	3LS 40-200/7.5	13.8	132S	B35	Fig 3	160	340	-	100	165	372	637	296	70	115	28	69	97	
	3LS 40-200/11.0	20.1	160M	B35	Fig 4	160	340	42	100	198	488	786	296	116	115	42	115	157	
	3LS 50-125/2.2	4.36	90L	B5	Fig 1	132	292	-	100	130	279	489	254	30	125	20	24	44	
	3LS 50-125/3.0	5.68	100L	B35	Fig 3	132	292	-	100	142	316	558	254	40	125	20	32	52	
	3LS 50-125/4.0	7.49	112M	B35	Fig 3	132	292	-	100	142	333	575	254	65	125	20	41	61	
	3LS 50-160/5.5	10.1	132S	B35	Fig 3	160	340	-	100	165	372	637	296	70	125	29	65	94	
65 mm x 80 mm	3LS 50-160/7.5	13.8	132S	B35	Fig 3	160	340	-	100	165	372	637	296	70	125	29	69	98	
	3LS 50-200/9.2	16.5	132M	B35	Fig 3	160	360	-	100	165	410	675	296	70	125	29	78	107	
	3LS 50-200/11.0	20.1	160M	B35	Fig 4	160	360	42	100	198	488	786	296	116	125	42	115	157	
	3LS 50-200/15.0	27.1	160M	B35	Fig 4	160	360	42	100	198	488	786	296	116	125	43	119	162	
	3LS 65-125/4.0	7.49	112M	B35	Fig 2	160	340	-	100	142	333	575	254	65	145	26	41	67	
	3LS 65-125/5.5	10.1	132S	B35	Fig 3	160	340	-	100	165	372	637	254	91	145	28	65	93	
	3LS 65-125/7.5	13.8	132S	B35	Fig 3	160	340	-	100	165	372	637	254	91	145	29	69	98	
	3LS 65-160/9.2	16.5	132M	B35	Fig 3	160	360	-	100	165	410	675	296	70	145	30	78	108	
	3LS 65-160/11.0	20.1	160M	B35	Fig 4	160	360	42	100	198	488	786	296	116	145	40	115	155	
	3LS 65-160/15.0	27.1	160M	B35	Fig 4	160	360	42	100	198	488	786	296	116	145	42	119	162	
80 mm x 100 mm	3LS 65-200/15.0	27.1	160M	B35	Fig 3	180	405	-	100	208	488	696	296	116	145	30	119	149	
	3LS 65-200/18.5	33.3	160L	B35	Fig 3	180	405	-	100	208	532	840	296	116	145	30	136	166	
	3LS 65-200/22	38.8	180M	B35	Fig 5	180	405	-	100	208	554	862	296	131	145	30	176	206	
	3LS 65-250/30	53.3	200L	B35	Fig 5	200	450	-	100	208	657	965	400	117	150	70	244	314	
	3LS 65-250/37	65.6	200L	B35	Fig 5	200	450	-	100	208	657	965	400	117	150	71	265	336	
	3LS 80-160/11	20.1	160M	B35	Fig 3	180	405	-	125	208	488	821	350	89	150	52	115	167	
	3LS 80-160/15	27.1	160M	B35	Fig 3	180	405	-	125	208	488	821	350	89	150	52	119	171	
	3LS 80-160/18.5	33.3	160L	B35	Fig 3	180	405	-	125	208	532	865	350	89	150	53	136	189	
3LS 80-200/22	38.8	180M	B35	Fig 5	180	430	-	125	208	554	887	357	101	150	68	176	244		
3LS 80-200/30	53.3	200L	B35	Fig 6	180	430	20	125	208	657	990	400	117	150	72	244	316		
3LS 80-200/37	65.6	200L	B35	Fig 6	180	430	20	125	236	657	1018	400	117	150	73	265	338		
3LS 80-250/45	77.6	225SM	B35	Fig 6	200	480	25	125	236	746	1107	450	183	150	88	416	504		
3LS 80-250/55	93.5	250SM	B35	Fig 7	200	480	80	125	248	825	1198	550	133	150	100	485	585		

Specifications subject to change without notice

Flanges to DIN 2532

32,40,50 & 65 Ø mm

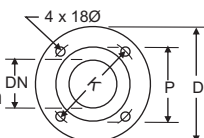

80 & 100 Ø mm

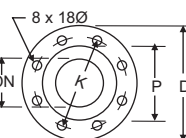

DN	32	40	50	65	80	100
P	75	80	95	115	120	135
K	100	110	125	145	160	180
D	140	150	165	185	200	225

- A** Typical with stamped casing
(i.e. all 32, 40 & 50 mm & 65 -125/160/200)
- B** Typical with cast casing
(i.e. 65-250, & all 80)

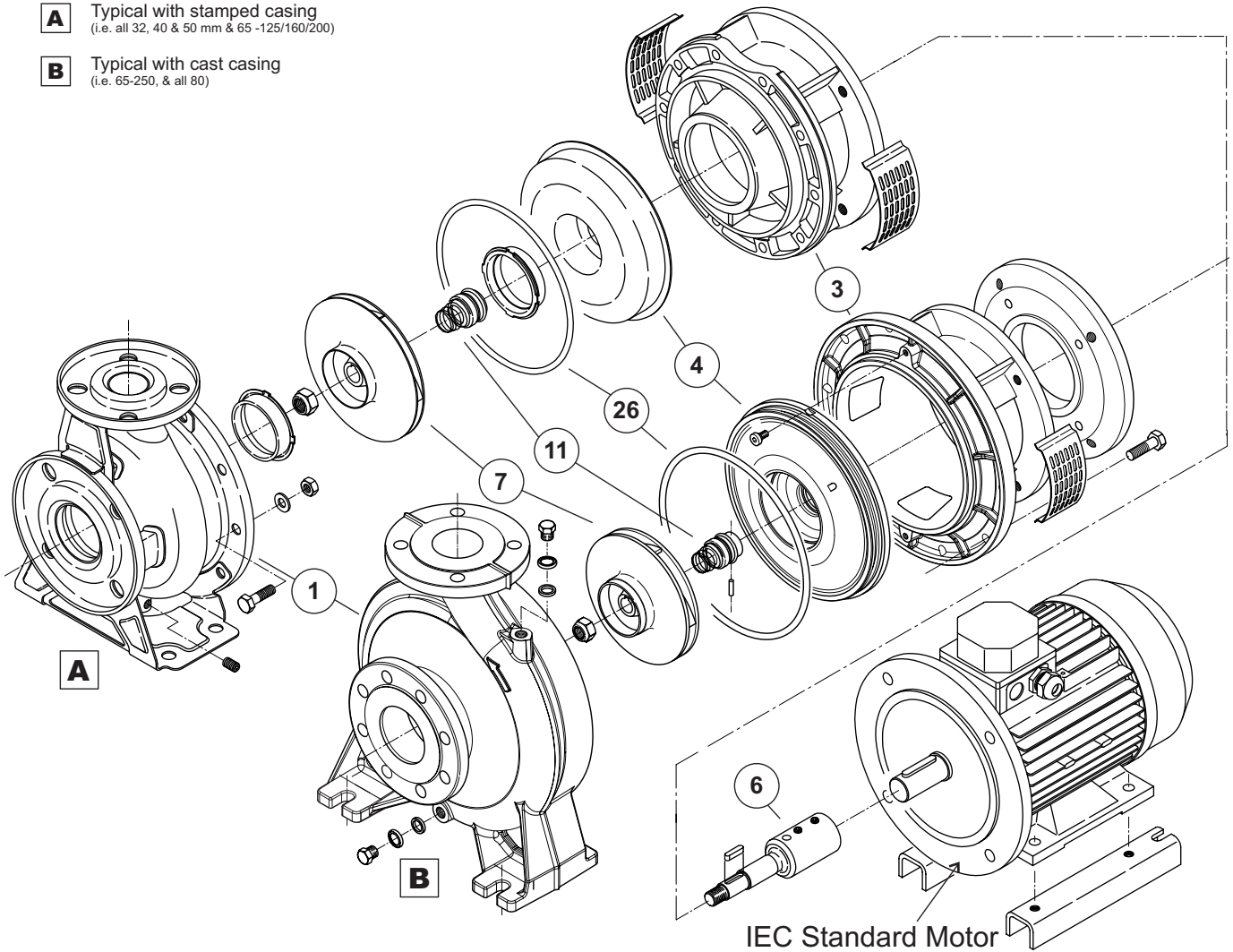

Note: Mounting and support feet varies between models.

Item	Description	Suits models	Materials
1	Casing	All 32, 40 & 50; 65-125/160/200	316L Stainless Steel - <i>stamped</i>
		65-250; All 80	316 Stainless Steel - <i>precision cast</i>
7	Impeller	All 32, 40 & 50	316L Stainless Steel - <i>stamped</i>
		All 65 & 80	316 Stainless Steel - <i>precision cast</i>
4	Casing cover	32, 40 & 50; 65-125/160/200; 80-160	316L Stainless Steel - <i>stamped</i>
		65-250; 80-200/250	316 Stainless Steel - <i>precision cast</i>
26	O-Ring (casing)	All models	Viton
11	Mechanical seal	All models	SiC/SiC/Viton with anti rotation device for stationary seat.
6	Stub shaft	All models	316 Stainless Steel (Up to 22 kW) Duplex Stainless Steel (30 to 55 kW)
3	Motor bracket	All models	Cast Iron

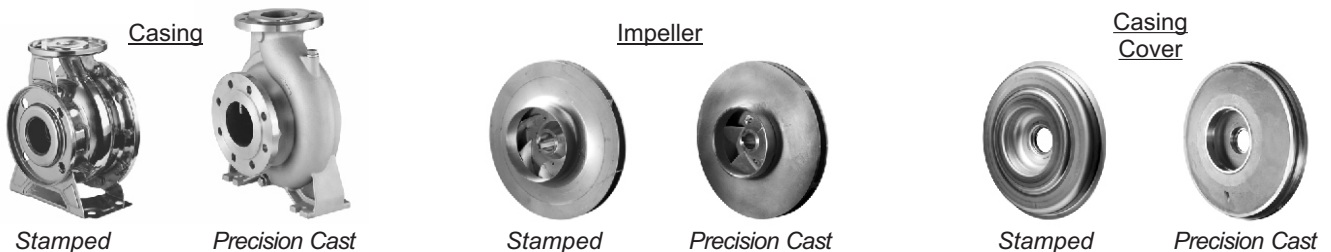

Specifications subject to change without notice